



# Poetry Ribbons

Cathryn Ploehn



# Inspiration

"I know that when I meet my own life in a great poem, I feel opened, clarified, confirmed somehow in what I sensed was true but had no words for. Anything that can do this is surely necessary for the fullness of a human life."

- Roger Housden, author

All communication is translation. Translations are often thought of as a bridge from one idea to another, connecting gaps in language in culture.

What valuable meaning is lost in the act of translating poetry from one language to another? For every word used in a poem, multiple alternative words can be chosen. After translation, changes in syntax or poem structure change the resulting meaning.

How can modes of communication besides the written word be used to bring underlying layers of meaning? The cadence of words as they are spoken aloud – the hard

or softness of words combined with tone may reveal underlying intricate meanings.

Poems, like ribbons:

- Have a flowing/fluid quality, especially when read aloud
- Have changing feelings (textures), emotions (colors), and mood (contexts)

**Exploring this metaphor, Poetry Ribbons will be a system that translates poetry through alternative modalities, such as sound and imagery, allowing the exploration of meaning in varying languages and methods.**

# End goals

**Develop a system that provides a multi-modal translation of poetry**

- visualization and/or sonification of poetry
- translations (if they exist) and synonyms to words
- The system will utilize an API to interact with a database of poetry and supplementary resources

**Provide an engaging experience that heightens understanding of poetic material**

- Bolster student understanding of works

# Measures of Success

## 1. The system successfully provides:

- Visualization of a poem's content
- An easy to use way to read through translation(s) of a poem

2. An API is built or extended for working with poetry and related material

3. Positive user feedback/criticism



# Constraints

- Copyrights
- Scalability
- Acquiring library of words, translations
- Acquiring poem readings, formatting sound



# Target Audience

## The student.

A potentially inquisitive person, yet not always enthusiastic about the cryptic nature of poetry. The student may become interested in the multimodal approach and interactions possible. May be used as a tool for exploration.

### Questions a student could ask:

- How can I better understand poetry?
- Why do I care about poetry?
- How does poetry help me in life?
- How can I apply poetry to life?
- Is this even fun?

### What can students get out of this?

- Deeper understanding of translated works
- Appreciation of other cultures
- empathy

# Tools to be used

## Database:

Build API with Apigee (usergrid)

## Interface:

HTML/CSS

Javascript

# Tools to be used

## Database:

Build API with Apigee (usergrid)

## Interface:

HTML/CSS

Javascript

- ThreeAudio.js
- SoundJS
- Web Audio API

Processing



# Major milestones

Learn background knowledge,  
Refine project plan

Research users,  
gather data about practices and goals

Planning: construction of mental models and project requirements

Sketching and interface design. Design of interactions

Prototype development (high fidelity)

Quality assurance (testing)

---

2 weeks  
1/13- 1/27

2 weeks  
1/27-2/10

2 weeks  
2/10-2/24

2 weeks  
2/24-3/10

7 weeks  
3/17-5/5

1 weeks  
5/5-5/12

# Competition

## Poem viewer, [ovii.oerc.ox.ac.uk/poemvis](http://ovii.oerc.ox.ac.uk/poemvis)

- displays phonetic units and attributes
- indicates phonetic relations, features
- displays word units and attributes
- indicates repeated words

### Criticisms:

- Introduces cryptic system of poem dissection, hard to learn the language
- geared towards the translator

## Poetry, Poetry Foundation

- Based on keywords: "passion," etc
- "spin" interaction: animates and generates random poetry to read
- Easy to use

### Criticisms

- Presents poetry as static text
- Reading interface doesn't provide added value

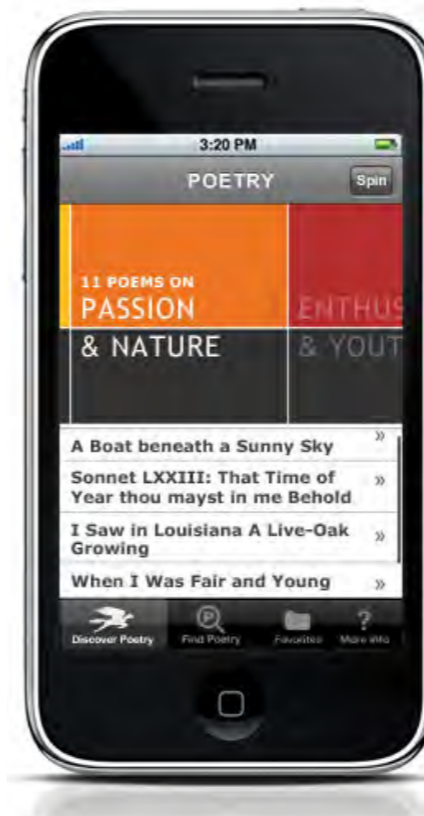
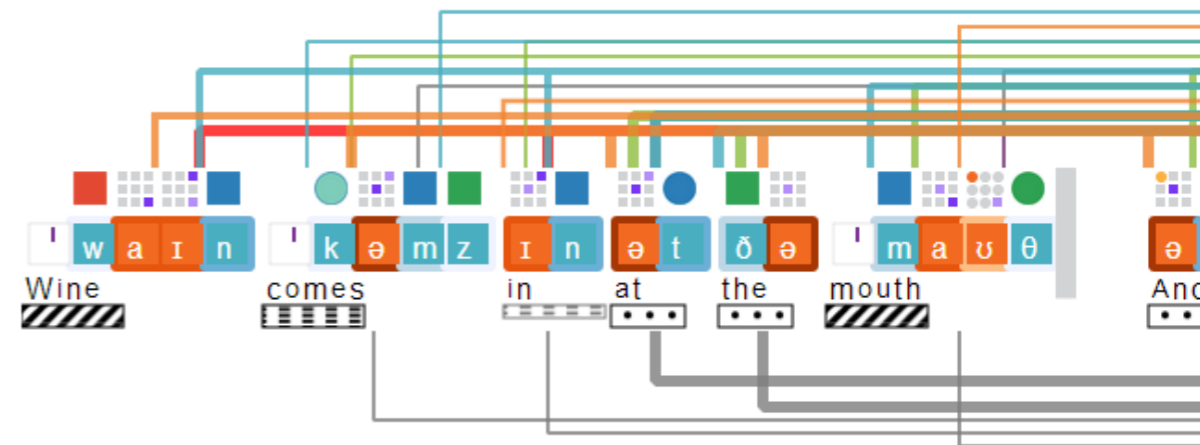

# Competition

## Poem Flow

- Allows poems to be read line by line
- clutter free screen
- geolocation, social sharing



## The Poetry App

- Provides audio/video of poems
- poems are read aloud
- skeumorphic interface

